

# The Smart Escape from Conventional drive Problems

More and more boat owners are turning to Saildrive power as the smart alternative to the problems of conventional stern tube shaft drives. The beautiful simplicity of this compact drive system makes it the sensible choice for numerous types of boats. Not only is reliability a big element in these designs but also stability, as they eliminate shaft vibrations, noise, alignment and stuffing box problems.

The logical power-to-prop direct drive combines all the advantages of the

outdrive-inboard systems and has now been well accepted in boating circles. The Saildrive has been found to improve boat balance, give more maneuverability and better thrust.

Driven by the famous Yanmar diesels, these Saildrives put a lot of dependable power in the right place in a boat.

Easily installed with a toughened, thru-hull fitting, the new SD40-4T drive unit smoothly takes the rugged power of the JH diesels, which are now expanded up to 75hp.

## SPECIFICATIONS

Engine series	GM					JH3			
Engine model	<b>1GM10C</b>	<b>2GM20C</b>	<b>2GM20FC</b>	<b>3GM30C</b>	<b>3GM30FC</b>	<b>3JH3CE</b>	<b>4JH3CE1</b>	<b>4JH3-TCE</b>	
No. of cylinders	1	2		3		3	4		
Bore x stroke	mm(in.) 75x72(2.95x2.83)					84x90(3.31x3.54)			
Displacement	liter(in <sup>3</sup> )	0.318(19.41)	0.636(38.81)	0.954(58.22)	1.496(91.29)	1.995(121.74)	1.995(121.74)		
Max. output	kW(hp)/min <sup>-1</sup>	7(9)/3600	13(18)/3600	20(27)/3600	29(40)/3800	41(56)/3800	55(75)/3800		
Cont. output	kW(hp)/min <sup>-1</sup>	6(8)/3400	12(16)/3400	18(24)/3400	27(36)/3650	37(50)/3650	51(69)/3700		
Combustion system	Special swirl type pre-combustion chamber					Direct injection			
Starting system	Electric with manual	Electric	Electric with manual	Electric	Electric				
Cooling system	Seawater cooling	Fresh water cooling	Seawater cooling	Fresh water cooling	Fresh water cooling				
Lubricating system	Forced lubrication with trochoid pump					Forced lubrication with trochoid pump			
Mounting size	SAE#6					SAE#5	SAE#4		
Saildrive model	<b>SD20</b>					<b>SD40</b>	<b>SD40-4T</b>		
Reduction gear system	Constant mesh gear with dog clutch					cone clutch			
Reduction ratio Ahead/Astern	2.64/2.64					2.32/2.32			
Propeller speed at cont. rating	min <sup>-1</sup>	1289				1576	1597		
Direction of rotation	Input shaft	Counterclockwise viewed from stern				Counterclockwise viewed from stern			
	Propeller shaft	Clockwise viewed from stern				CC/CW viewed from stern			
Lubricating system	Oil bath					Oil bath			
Dry weight, engine with saildrive	kg(lbs)	104(229)	134(295)	142(313)	153(337)	161(355)	206(453)	243(535)	
Lubrication oil for saildrive	API CC and SAE 10W30	API GL4 or GL5 and SAE 80W90 or 90				API GL4 or GL5 and SAE 80W90 or 90, or Quicksilver High Performance Gear Lube		Quicksilver High Performance Gear Lube	

Rating condition: ISO-3046/1 Note:hp 0.7355kW  
Use only Quicksilver High Performance Gear Lube in SD40-4T  
Propeller with Rubber bushing must be used in all SD series saildrives

### 3GM30C x SD20

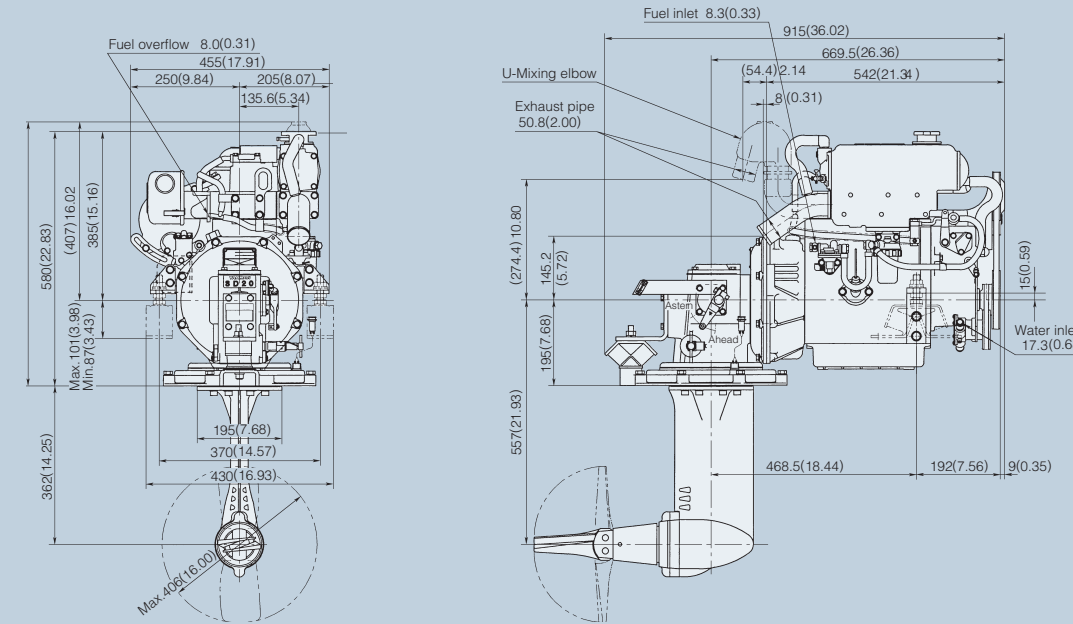

### 3GM30FC x SD20

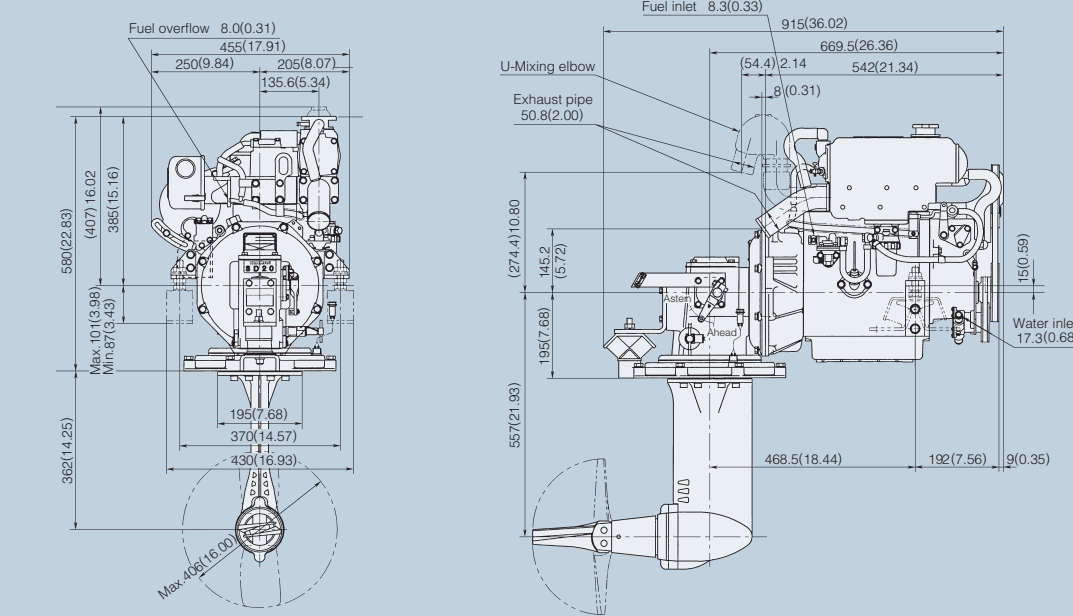

### 3JH3CE x SD40

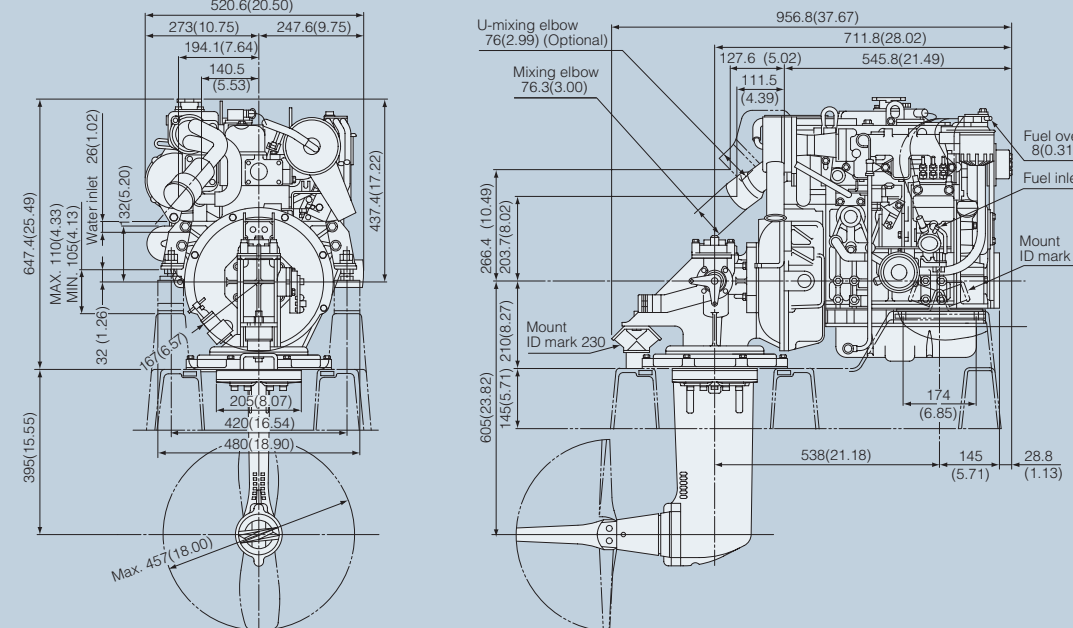

### 4JH3CE1 x SD40

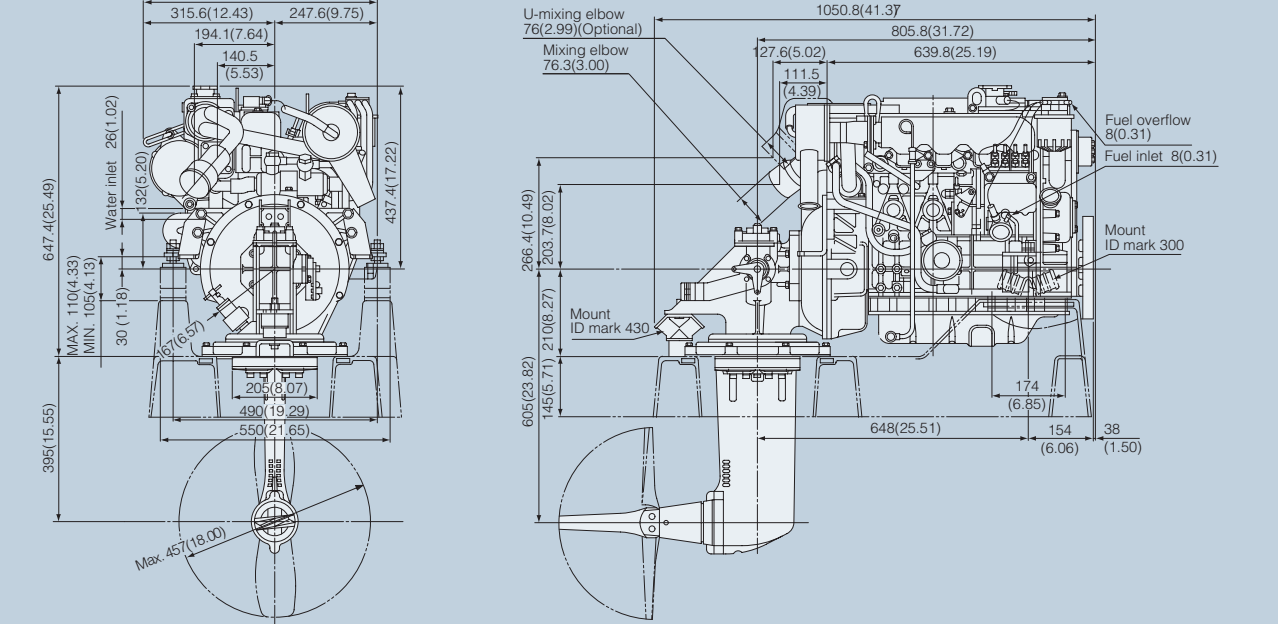

### 4JH3-TCE x SD40-4T

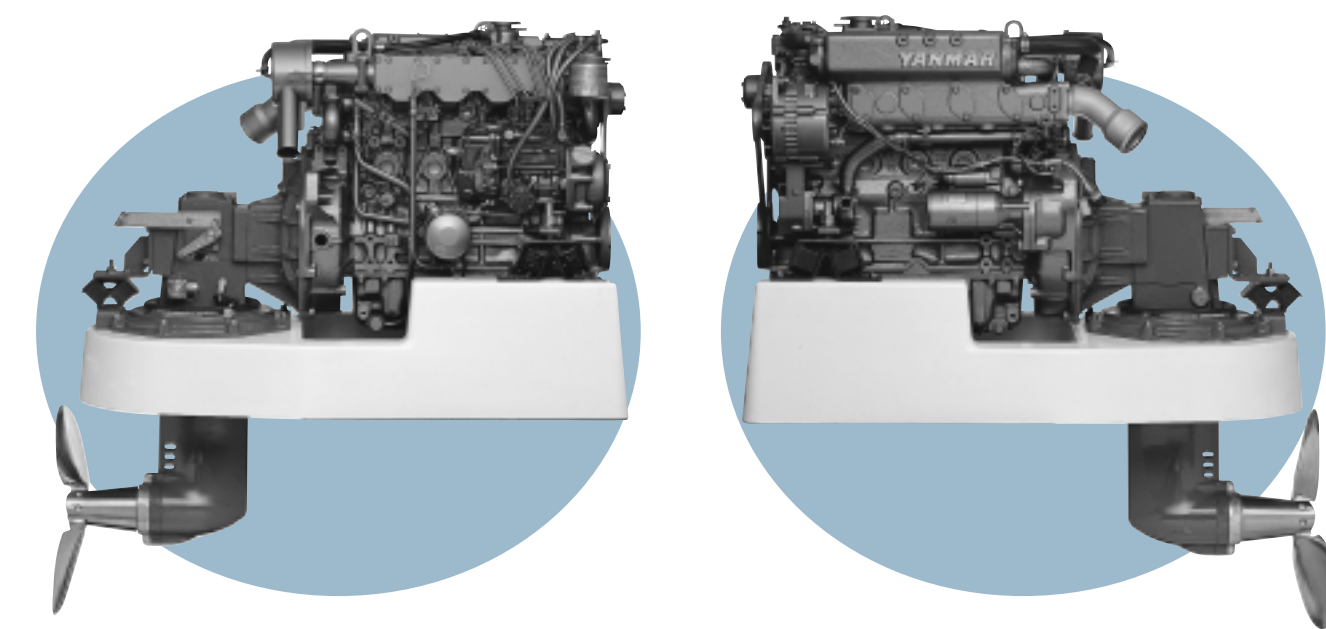
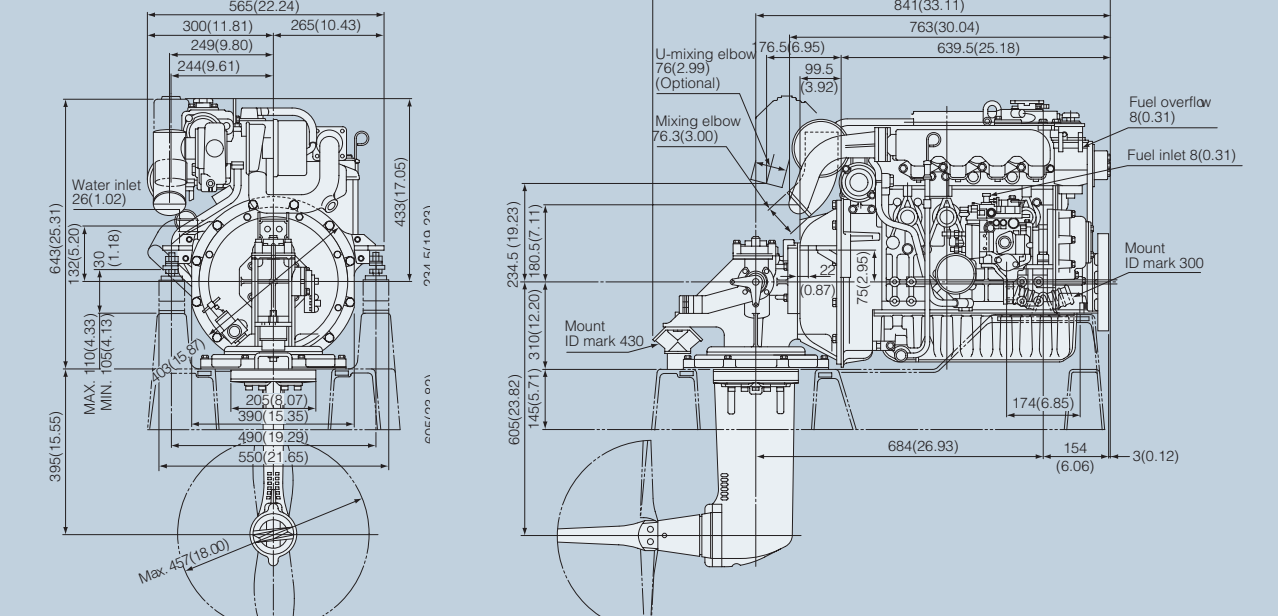



Unit: mm (in.)

**1GM10C x SD20**

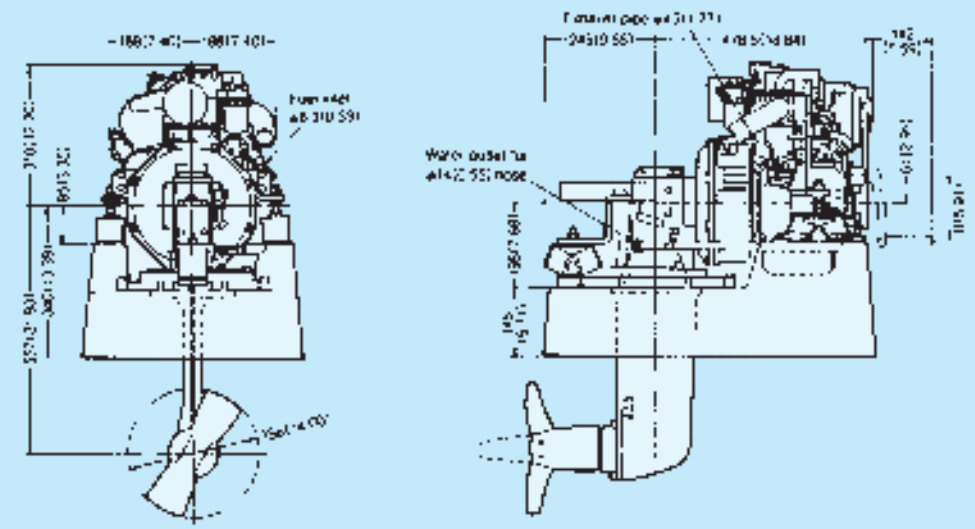

**2GM20C x SD20**

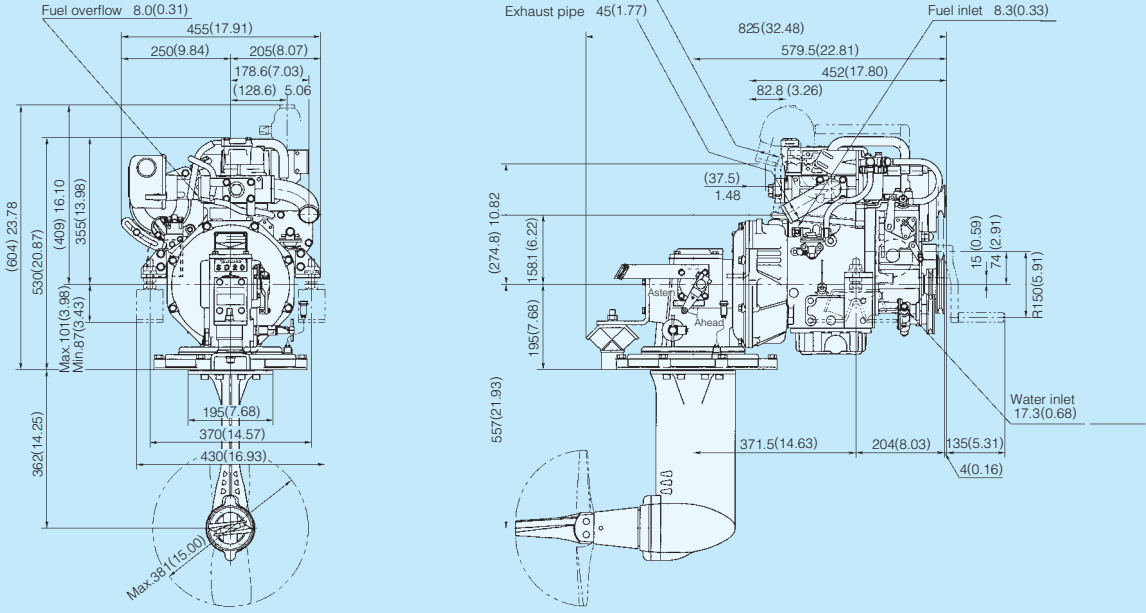

**2GM20FC x SD20**

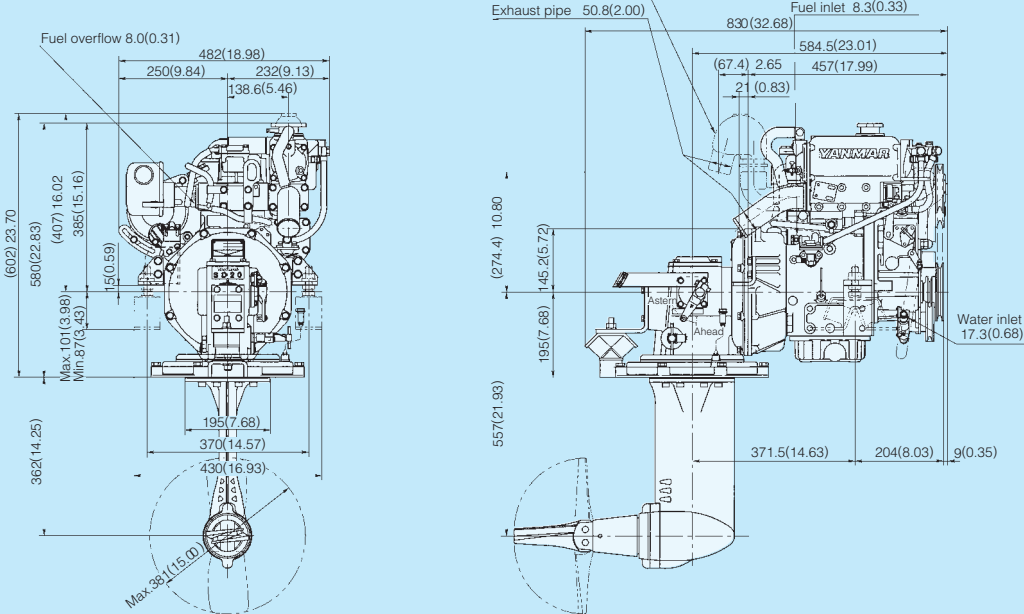

**PERFORMANCE CURVES**

**1GM10C**

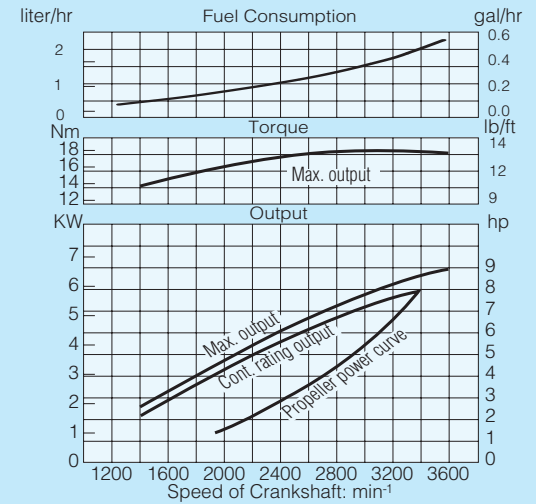

**2GM20C/2GM20FC**

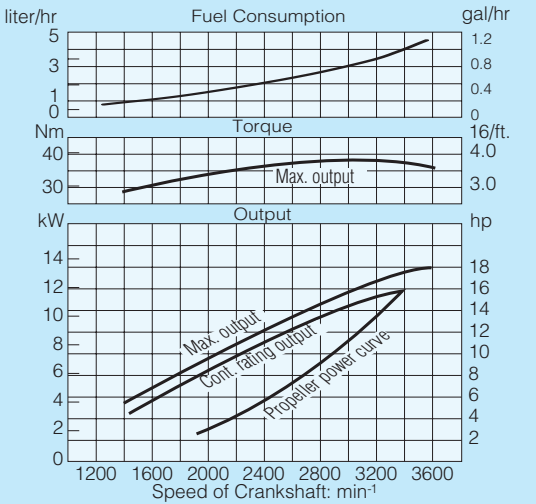

**3GM30C/3GM30FC**

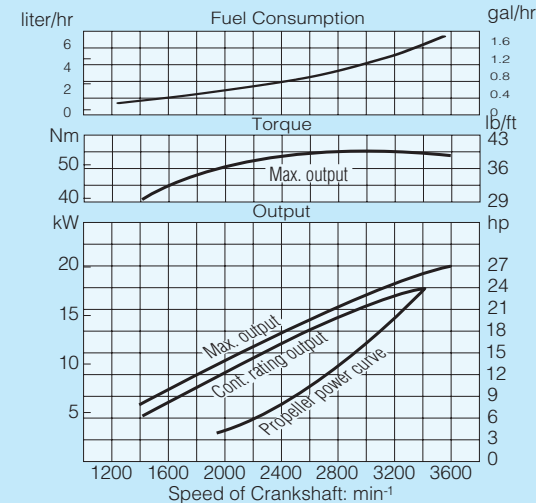

**3JH3CE**

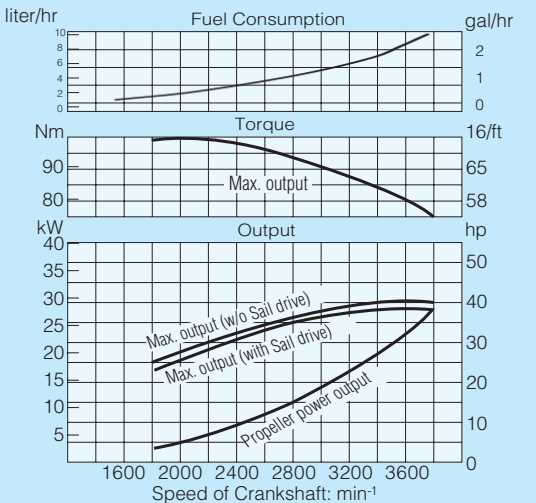

**4JH3CE1**

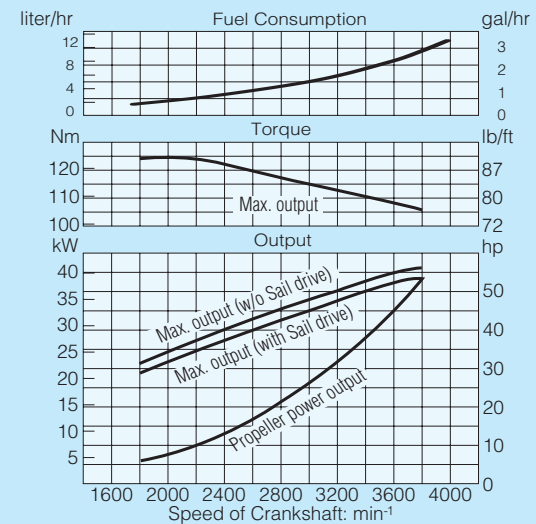

**4JH3-TCE**

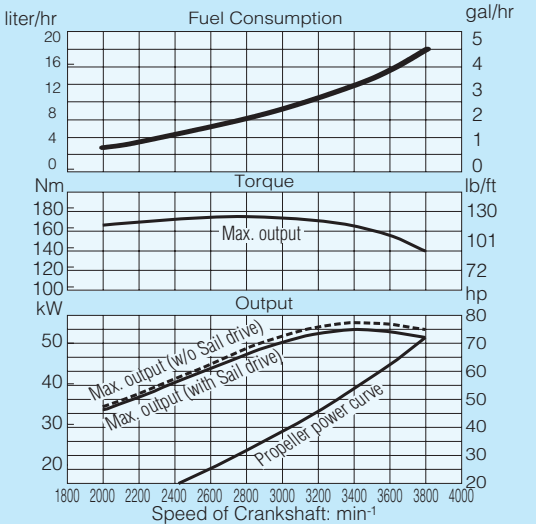

**MARINE DIESEL ENGINES**  
PLEASURE-CRAFT POWER

**SAILDRIVE series**  
7~55kW (9~75hp)

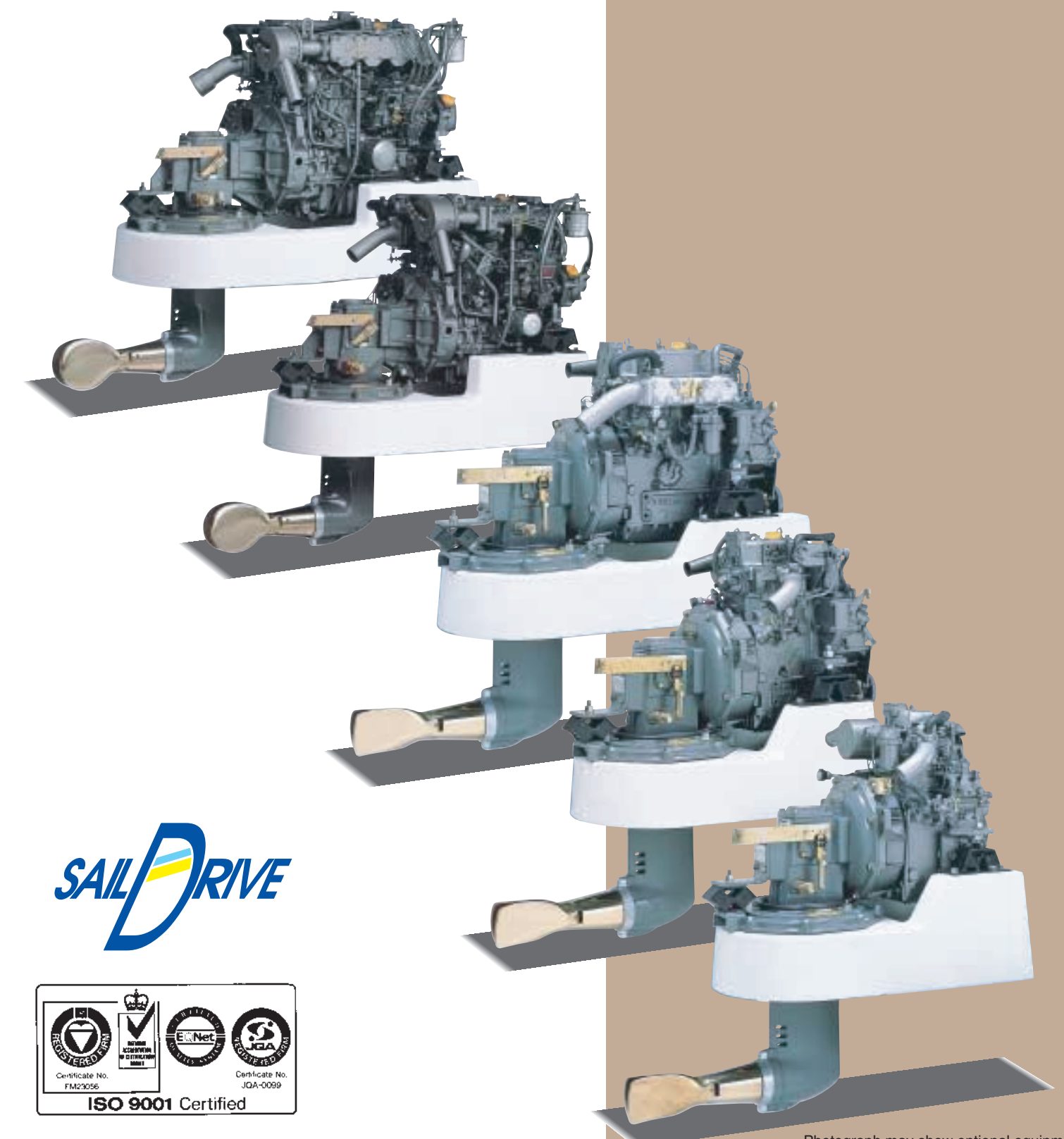

Note: All data subject to alteration without notice.

YANMAR DIESEL AMERICA CORP. 901 Corporate Grove Drive, Buffalo Grove, IL 60089  
 YANMAR EUROPE B.V. Brugplein 11 1332 BS Almere-de Vaart, The Netherlands  
 YANMAR DIESEL ENGINE CO., LTD. 1-2, 2-chome, Yaesu, Chuo-ku, Tokyo 104, Japan  
 www.yanmar.com  
 60ASD-10/01 5M Printed in the USA

Photograph may show optional equipment.