

6HYM-WET Series

LONG STROKE | IMO Tier II Compliant | Mechanical Engine Control

Configuration	4-cycle, Vertical, Turbo-charged with sea watercooled intercooler diesel engine	
Maximum output at crankshaft	S: 515 kW@2200 rpm [for planing hull] [700 mhp@2200 rpm] L: 478 kW@2150 rpm [650 mhp@2150 rpm] M: 441 kW@2100 rpm [600 mhp@2100 rpm] H: 368 kW@1950 rpm [500 mhp@1950 rpm]	
Displacement	13.733 ltr	
Bore x stroke	132.9 mm x 165 mm	
Cylinders	6 in-line	
Combustion system	Direct injection	
Starting system	Electric starting motor [DC 24V]	
Flywheel housing size	SAE #1, 14 inch	
Cooling system	Constant high temperature cooling with Heat exchanger	
Cooling fresh water capacity	40 ltr + 1.5 ltr [reservoir tank]	
Lubrication system	Forced lubrication with gear pump	
Lubricating oil capacity	36 ltr	
Lubricating oil grade	SAE30, 40 or SAE15W-40	
Direction of rotation [crankshaft]	Counterclockwise viewed from stern	
Dry weight without gear	1385 kg	
Environmental	IMO Tier II	
Fuel consumption [at rated output]	S: 210 gr/kW hr M: 207 gr/kW hr	L: 210 gr/kW hr H: 203 gr/kW hr

DIMENSIONS [UNIT: MM]

S/L/M-rating

Front view, engine only

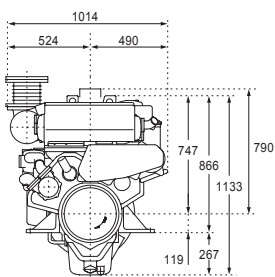

Right side view, engine only

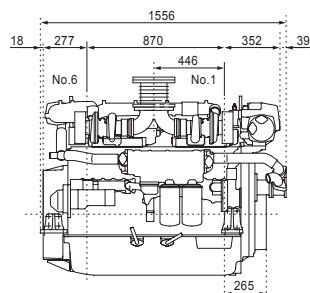

Rear view with YXH160 gearbox

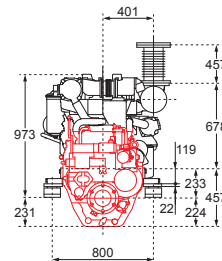

Right side view with YXH160 gearbox

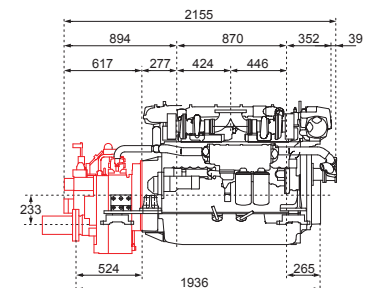

H-rating

Front view, engine only

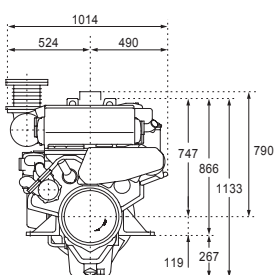

Right side view, engine only

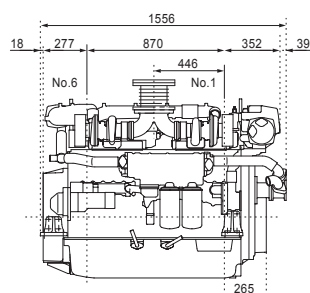

Rear view with gearbox YX161L [not for S rating]

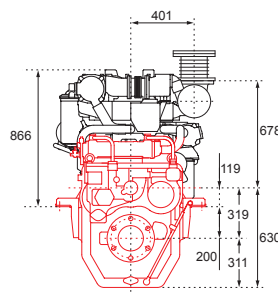

Right side view with gearbox YX161L [not for S rating]

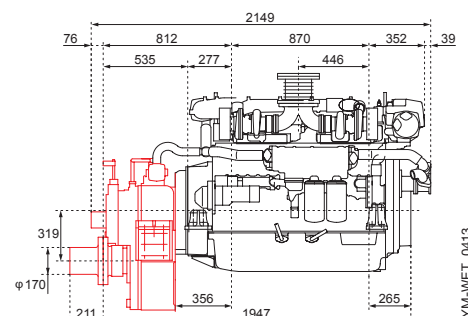

PERFORMANCE CURVES

S-rating

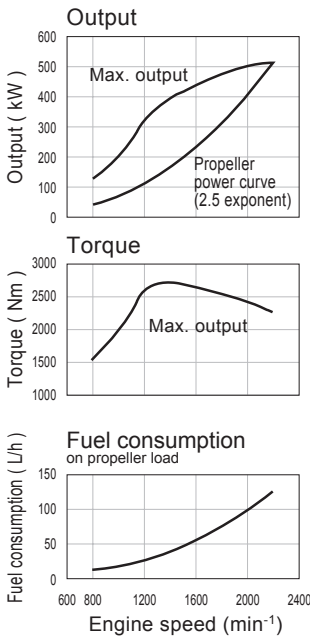

L-rating

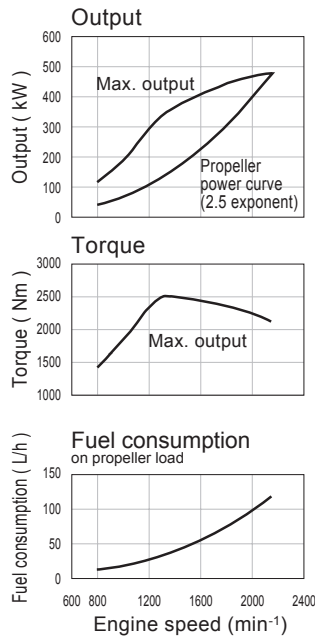

M-rating

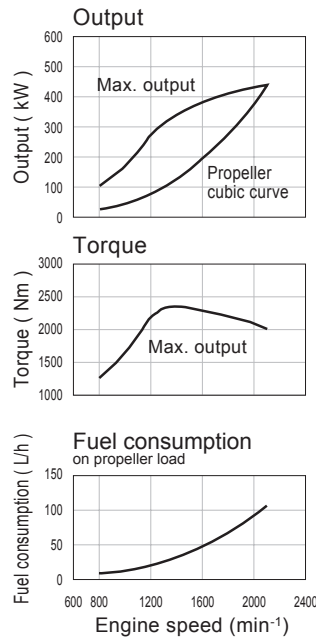

H-rating

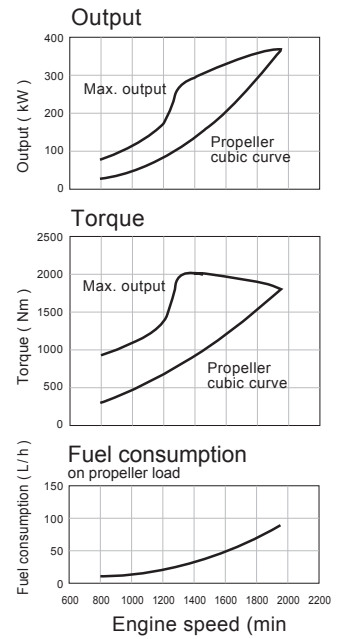

Rating definitions: hp = 0.7355 kW Ratings are based on conditions of 100 kPa, 30% relative humidity at 25°C.
 S= For applications where use of rated power is less than 30 minutes continuous out of every 90 minutes and operation is less than 1000 hours per year. When combined with a correctly matched propeller which allows the engine rated speed to be achieved in a fully loaded vessel state, the reduced-power operation can be at or below 50 rpm of the rated speed.
 L= For applications where use of rated power is less than 2 hours continuous out of every 5 hours and operation is less than 2000 hours per year. When combined with a correctly matched propeller which allows the engine rated speed to be achieved in a fully loaded vessel state, the reduced-power operation can be at or below 50 rpm of the rated speed.

M= For applications where use of rated power is less than 10 hours continuous out of every 16 hours and operation is less than 3000 hours per year. When combined with a correctly matched propeller which allows the engine rated speed to be achieved in a fully loaded vessel state, the reduced-power operation can be at or below 50 rpm of the rated speed.
 H= For applications where use of rated power is less than 24 hours continuous and operation is less than 4000 hours per year.
 Fuel rates: Specific gravity 0.835 g/cc, low calorific value 42700 kJ/kg [10200 kcal/kg], Cetane No.45.

MARINE GEARS SPECIFICATIONS

Model	YXH-160			YX-161L [not for S rating]		
Type	Hydraulic multi-disc clutch					
Dry Weight	390 kg			620 kg		
Reduction Ratio [Ahead]	1.97	2.46	3.05	3.65	4.08	4.55
Prop. shaft speed [at rated output]	990	793	639	534	480	429
Direction of rotation [propeller shaft]	Clockwise or counter-clockwise viewed from stern					

INSTRUMENT PANEL D-TYPE [UNIT: MM]

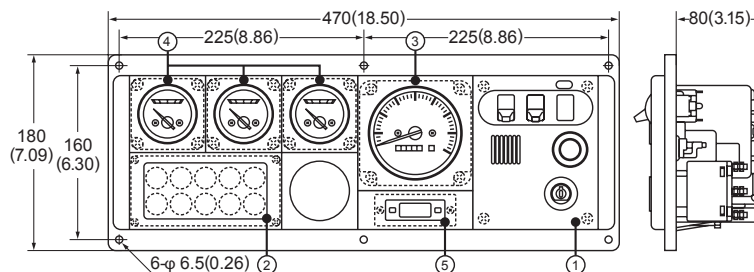

1 Switch unit

- Key switch
- Alarm buzzer
- Alarm buzzer stop switch
- Illumination switch

2 Alarm lamp unit with Alarm monitor device

- Battery not charging
- C.W. high temp.
- L.O. low pressure
- Clutch oil pressure
- L.O. filter clogged
- C.W.level

3 Tachometer unit

- Tachometer with hour meter

4 Sub meter unit

- L.O. pressure meter
- C.W. temp. meter
- Boost meter [Turbo]

5 Clock unit

- Clock

NOTE: All data subject to change without notice. Text and illustrations are not binding.